

Wrenchless Pencil Grinder

With Turbine Brake and Hose Swivel

Air Tool Manual – Safety, Operation and Maintenance

SAVE THIS DOCUMENT, EDUCATE ALL PERSONNEL

Models:

60051 - 1/8" Collet, 60,000 RPM

60052 - 3/32" Collet, 35,000 RPM



FIND THE MOST CURRENT OFFERING OF SUPPORT DOCUMENTS AND ACCESSORIES @ WWW.DYNABRADE.COM

⚠ WARNING

Read and understand this tool manual before operating your air tool. Follow all safety rules for the protection of operating personnel as well as adjacent areas. Always operate, inspect and maintain this tool in accordance with the American National Safety Institute (ANSI) Safety Code for Portable Air Tools – B186.1. For additional safety information, refer to Safety Requirements for the Use, Care and Protection of Abrasive Wheels – ANSI B7.1, Code of Federal Regulation – CFR 29 Part 1910, European Committee for Standards (EN) Hand Held Non-Electric Power Tools – Safety Requirements and applicable State and Local Regulations.

SAFETY LEGEND

	⚠ WARNING Read and understand tool manual before work starts to reduce risk of injury to operator, visitors, and tool.	⚠ WARNING Practice safety requirements. Work alert, have proper attire, and do not operate tools under the influence of alcohol or drugs.	
	⚠ WARNING Eye protection must be worn at all times, eye protection to conform to ANSI Z87.1.	⚠ WARNING Ear protection to be worn when exposure to sound, exceeds the limits of applicable Federal, State or local statutes, ordinances and/or regulations.	
	⚠ WARNING Respiratory protection to be used when exposed to contaminants that exceed the applicable threshold limit values required by law.	⚠ WARNING Air line hazard, pressurized supply lines and flexible hoses can cause serious injury. Do not use damaged, frayed or deteriorated air hoses and fittings.	

⚠ WARNING

Some dust created by sanding, sawing, grinding, drilling, and other construction activities contain chemicals known to cause cancer, birth defects or other reproductive harm. Some examples of these chemicals are:

- Lead from lead-based paints
- Crystalline silica from bricks and cement and other masonry products
- Arsenic and chromium from chemically treated lumber

Your risk from these exposures varies, depending on how often you do this type of work. To reduce your exposure to these chemicals: work in a well ventilated area, and work with approved safety equipment, such as those dust masks that are specially designed to filter out microscopic particles.

SAFETY INSTRUCTIONS

Carefully Read all instructions before operating or servicing any Dynabrade® Abrasive Power Tool.

Products offered by Dynabrade are not to be modified, converted or otherwise altered from the original design without expressed written consent from Dynabrade, Inc.

Tool Intent: Pencil Grinder Tools are ideal for engraving, light deburring, deflashing, surface preparation, cleaning and finishing using the proper abrasive stones, abrasive mounted wheels, points, molded abrasives, and carbide burrs.

Do not use tool for anything other than its intended applications.

This power tool is not intended for use in potentially explosive atmospheres and is not insulated against contact with electrical power.

Training: Proper care, maintenance, and storage of your tool will maximize performance.

- Employer's Responsibility – Provide Pencil Grinder operators with safety instructions and training for safe use of tools and accessories.

Accessory Selection:

- Abrasive/accessory RPM (speed) rating MUST be approved for AT LEAST the tool RPM rating.

(continued on next page)

SAFETY INSTRUCTIONS (Cont.)

- Before mounting an accessory, visually inspect for defects. Do not use defective accessories.
- Use only accessories of the correct mandrel size for the collet.
- Follow tool specifications before choosing size and type of accessory.
- Only use recommended fittings and air line sizes. Air supply hoses and air hose assemblies must have a minimum working pressure rating of 150 PSIG (10 Bars, g) or 150 percent of the maximum pressure produced in the system, whichever is higher. (See tool Machine Specifications table.)
- If a mounted wheel is broken, a careful investigation should be made by the user to determine and correct the cause.

OPERATING INSTRUCTIONS

Warning: Always wear personal protection equipment. Operator of tool is responsible for following: accepted eye, face, respiratory, hearing and body protection. Adjacent personnel must be protected from potential injury.

Warning: Be sure that any loose clothing, hair and all jewelry is properly restrained. Keep hand and clothing away from working end of the air tool.

Warning: Do Not use cut-off wheels or router bits.

Caution: Hand, wrist and arm injury may result from repetitive work, motion and overexposure to vibration.

MANDREL ACCESSORY MOUNTING INSTRUCTIONS

With Power Source Disconnected from the Tool, Mount Recommended Accessory

- Check the collet insert to assure it is clean and in good condition.
- Check the mandrel diameter of the accessory to insure it matches the collet insert size exactly. i.e. 1/8" shaft – 1/8" collet insert.
- Rotate the lever 90 degrees to the housing to fully open the collet insert.
- Insert the mandrel of the accessory a minimum of 1 inch into the collet insert.
- Adjust the collet by rotating the insert until mandrel slides freely but not loose inside the collet.
- Rotate the lever parallel to the housing until it detents into place.
- Insure the mounted accessory is properly secured in the collet by pulling on the accessory. Repeat steps above if the accessory is not properly secured.

Warning: Overhang (end of collet to abrasive) affects RPM rating and may create a hazard. Refer to the included ANSI B7.1 Table 27. Reference ANSI B7.1 for a more complete listing and additional information.

- Long mandrel accessories are subject to bending, whipping and breaking when run at high speeds.

Caution: After installing the accessory, before testing or using and/or after assembling tool, the Pencil Grinder must be started at a reduced speed to check for good balance.

- Make sure no one is in the unguarded plane of the wheel.
- Gradually increase tool speed.
- DO NOT USE if tool vibration is excessive. Correct cause, and retest to insure safe operation.
- Run tool for one minute at operating speed in a protected area.

- BEFORE MOUNTING AN ACCESSORY, after all tool repairs and whenever a pencil grinder is issued for use, check tool RPM (speed) with tachometer with air pressure set at 90 PSIG while the tool is running. If tool is operating at a higher speed than the RPM marked on the tool housing, or operating improperly, the tool must be serviced and corrected before use.

Caution: Tool RPM must never exceed abrasive/accessory RPM rating. Check accessory manufacturer for details on maximum operating speed or special mounting instructions.

- Make sure tool is off and connect power source. **Do not expose air tool to inlet pressure above 90 PSIG or (6.2 Bars).**
- Turn off inlet valve in case of an interruption of the energy supply.
- This tool should use filtered and regulated air, but does not require lubricated air. Lubricated air is not detrimental to tool life.

Caution: After installing the accessory, before testing or use and/or after assembling tool, the pencil grinder must be started at a reduced speed to check for good balance. Make sure no one is in the unguarded plane of the wheel. Gradually increase tool speed. DO NOT USE if tool vibration is excessive. Correct cause, and retest to insure safe operation. Run tool for 1 minute of operating speed in a protected area.

- Make sure that work area is uncluttered, and visitors are at a safe range from the tools and debris.
- Use a vise or clamping device to hold work piece firmly in place.
- Do not apply excessive force on tool or apply "rough" treatment to it.
- Always work with a firm footing, posture and proper lighting.
- Ensure that sparks and debris resulting from work do not create a hazard.

Warning: Sanding certain materials can create explosive dust. It is the employers responsibility to notify the user of acceptable dust levels. Reduce the risk by using dust collection systems and personal protective equipment.

- Tools exhaust may contain bearing grease. Direct exhaust away from operator.
- Use hearing protection when working with materials that produce high process noise levels. Permanent hearing loss can result from high sound levels.
- Do not set the tool down until the on/off valve is OFF and the tool has stopped turning.
- Always use dust extraction or suppression systems and personal protective equipment which are suitable for the materials being processed.

Report to your supervisor any condition of the tool, accessories, or operation you consider unsafe.

MAINTENANCE INSTRUCTIONS

Important: To keep tool safe a Preventative Maintenance Program is recommended for this tool. The program should include inspection of air supply lines, air line pressure and repair of tools. Refer to ANSI B186.1 for additional maintenance information.

- Use only genuine Dynabrade replacement parts to insure quality. To order replacement parts, specify **Model#**, **Serial#** and **RPM** of your air tool.
- All Dynabrade Air Tools must be used with a Filter-Regulator to maintain all warranties.

Routine Preventative Maintenance:

- Check free speed of pencil grinder using a tachometer every 20 hours of use or weekly, whichever occurs more frequently.
- Take special care in assembly of speed control protective device - turbine.
- An Air Line Filter-Regulator must be used with this air tool to maintain all warranties. Dynabrade recommends the following: 10677 Air Line Filter-Regulator – Provides accurate air pressure regulation, two-stage filtration of water contaminants. Operates 40 SCFM @ 90 PSIG has 3/8" NPT female ports.
- Mineral spirits are recommended when cleaning the tool and parts. Do not clean tool or parts with any solvents or oils containing acids, esters, ketones, chlorinated hydrocarbons or nitro carbons, or chemicals that have a low flash point (example: WD-40®).

MAINTENANCE INSTRUCTIONS - CONTINUED

Routine Preventative Maintenance:

- Air tool markings must be kept legible at all times. User is responsible for maintaining specification information i.e.: Model #, S/N, and RPM.
- Blow air supply hose out prior to initial use.
- Visually inspect air hoses and fittings for frays, visible damage and signs of deterioration. Replace damaged or worn components.
- Refer to Dynabrade's Warning/Safety Operating Instructions Tag (Reorder No. **95903**) for safety information.

Handling and Storage:

- Use of tool rests, hangers and/or balancers is recommended.
- Protect tool inlet from debris.
- **DO NOT** carry tool by air hose.
- **DO NOT** force grinding swarf into the tool with compressed air; specifically avoid the front bearing areas.
- Protect abrasive accessories from exposure to water, solvents, high humidity, freezing temperature and extreme temperature changes.
- Store accessories in protective racks or compartments to prevent damage.

Non-Lubricated Air System

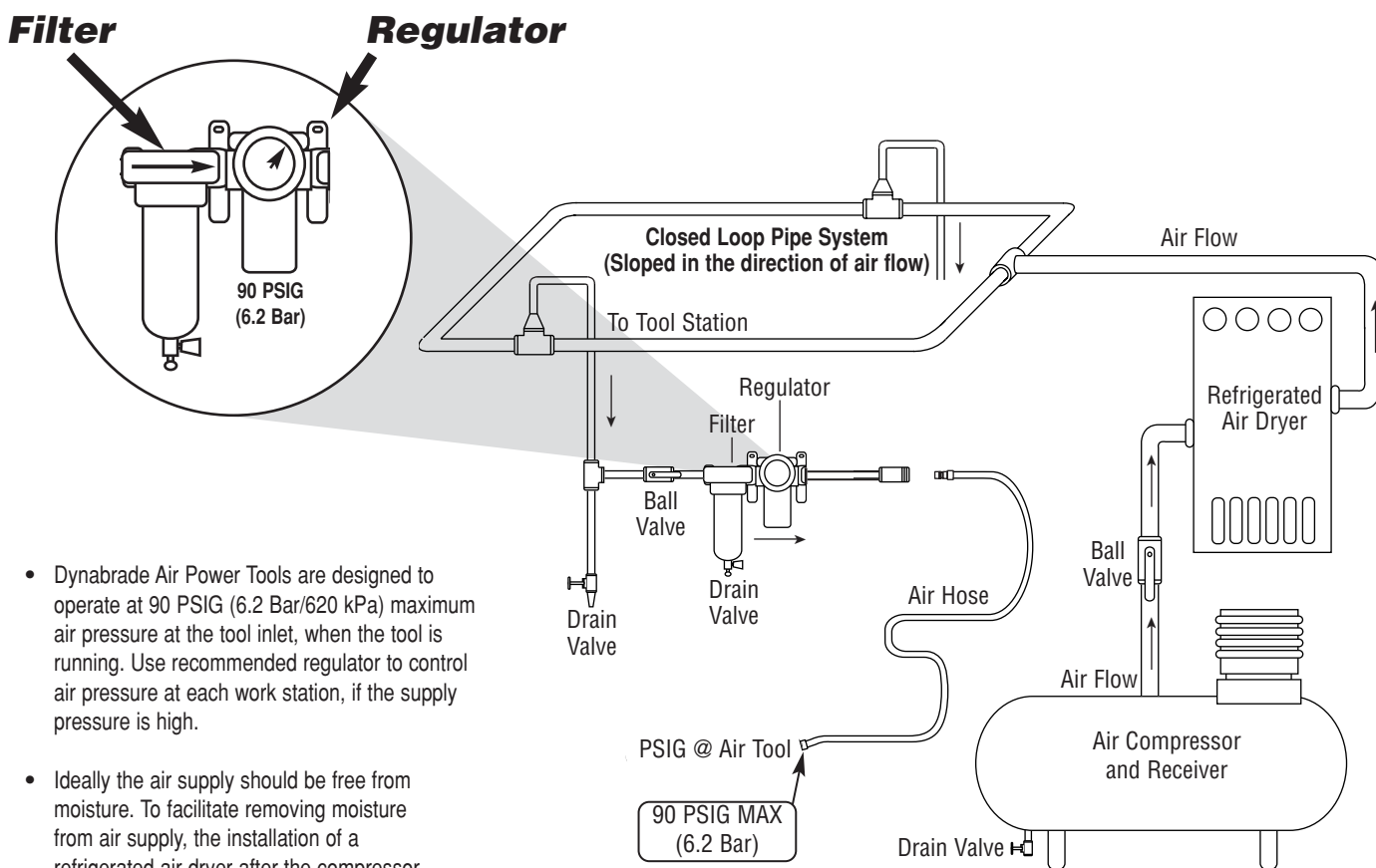

- Dynabrade Air Power Tools are designed to operate at 90 PSIG (6.2 Bar/620 kPa) maximum air pressure at the tool inlet, when the tool is running. Use recommended regulator to control air pressure at each work station, if the supply pressure is high.
- Ideally the air supply should be free from moisture. To facilitate removing moisture from air supply, the installation of a refrigerated air dryer after the compressor and the use of drain valves at each tool station is recommended.

Notice

All Dynabrade motors use the highest quality parts and metals available and are machined to exacting tolerances. The failure of quality pneumatic motors can most often be traced to an unclean air supply. Air pressure easily forces dirt or water contained in the air supply into motor bearings causing early failure. Dirt and water often score the inner workings of the tool resulting in limited efficiency and power. Our warranty obligation is contingent upon proper use of our tools and cannot apply to equipment which has been subjected to misuse such as unclean air, wet air or a lack of maintenance during the use of this tool.

Lifetime Warranty

All Dynabrade portable pneumatic power tools are rigorously inspected and performance tested in our factory before shipping to our customers. If a Dynabrade tool develops a performance problem and an inherent defect is found during normal use and service, Dynabrade will warrant this tool against defects in workmanship and materials for the lifetime of the tool. Upon examination and review at our factory, Dynabrade shall confirm that the tool qualifies for warranty status, and will repair or replace the tool at no charge to the customer. Normally wearable parts and products are NOT covered under this warranty. Uncovered items include bearings, contact wheels, rotor blades, regulators, valve stems, levers, shrouds, guards, O-rings, seals, gaskets and other wearable parts. Dynabrade's warranty policy is contingent upon proper use of our tools in accordance with factory recommendations, instructions and safety practices. It shall not apply to equipment that has been subjected to misuse, negligence, accident or tampering in any way so as to affect its normal performance. To activate lifetime warranty, customer must register each tool at www.dynabrade.com. Dynabrade will not honor lifetime warranty on unregistered tools. A one-year warranty will be honored on all unregistered portable pneumatic power tools. Lifetime warranty applies only to portable pneumatic tools manufactured by Dynabrade, Inc. in the USA. Lifetime warranty applies only to the original tool owner; warranty is non-transferable.

Models:
60051, 60052

Wrenchless Pencil Grinder Complete Assembly

Index Key

No.	Part #	Description
1	60076	1/8" Insert
	60108	3/32" Insert
2	60077	Bumper
3	60106	Tactile Grip
4	60066	Nose Piece
5	60081	Washer
6	60102	Spring
7	60087	Seal Washer
8	60088	Front Seal Washer
9	60089	Outer Housing Seal
10	60090	Inner Race Seal
11	60092	Rear Seal Washer
12	60093	Bearing
13	60074	End Support
14	60073	Spring Washer (20)
15	60078	Spring Washer Compressor
16	60091	Pin
17	60079	Collet Adjustment Screw
18	60064	Housing - 60051
	60065	Housing - 60052
19	60095	Pin
20	60080	Cam Support
21	60082	Cam
22	60107	Screw
23	60101	Lock Nut
24	60083	Lever
25	60085	Spring
26	60084	Plunger
27	60096	Detent Guide
28	51661	Wave Washer
29	51651	Bearing
30	60068	Drive Shaft
31	60098	Pin
32	51656	Turbine Base
33	51678	Turbine
34	51675	Governor - 60,000RPM
	51691	Governor - 35,000RPM
35	60069	Brake Plate
36	60099	Hex Nut
37	60103	Retaining Ring
38	60105	O-Ring
39	60075	Backing Plate
40	60072	Brake Assembly
41	51662	Bushing
42	60097	Spring
43	60104	O-Ring (2)
44	60100	Pin (2)
45	Turbine Cover	
	60110	35K - Red
	60111	60K - Turquoise
46	10967	Bearing
47	10966	Swivel Barb
48	10972	O-Ring
49	10968	Bearing
50	95998	Retaining Ring
51	51276	Hose (24in.)
52	51665	On/Off Valve
53	95730	O-Ring (2)
54	51669	Retaining Ring
55	51282	Valve Body
56	51664	Valve Seat
57	51663	Tip Valve
58	51676	Spring
59	51271	Barb Fitting
60	51277	Hose (42 in.)
61	51269	Barb Fitting
62	56022	Inlet Screen

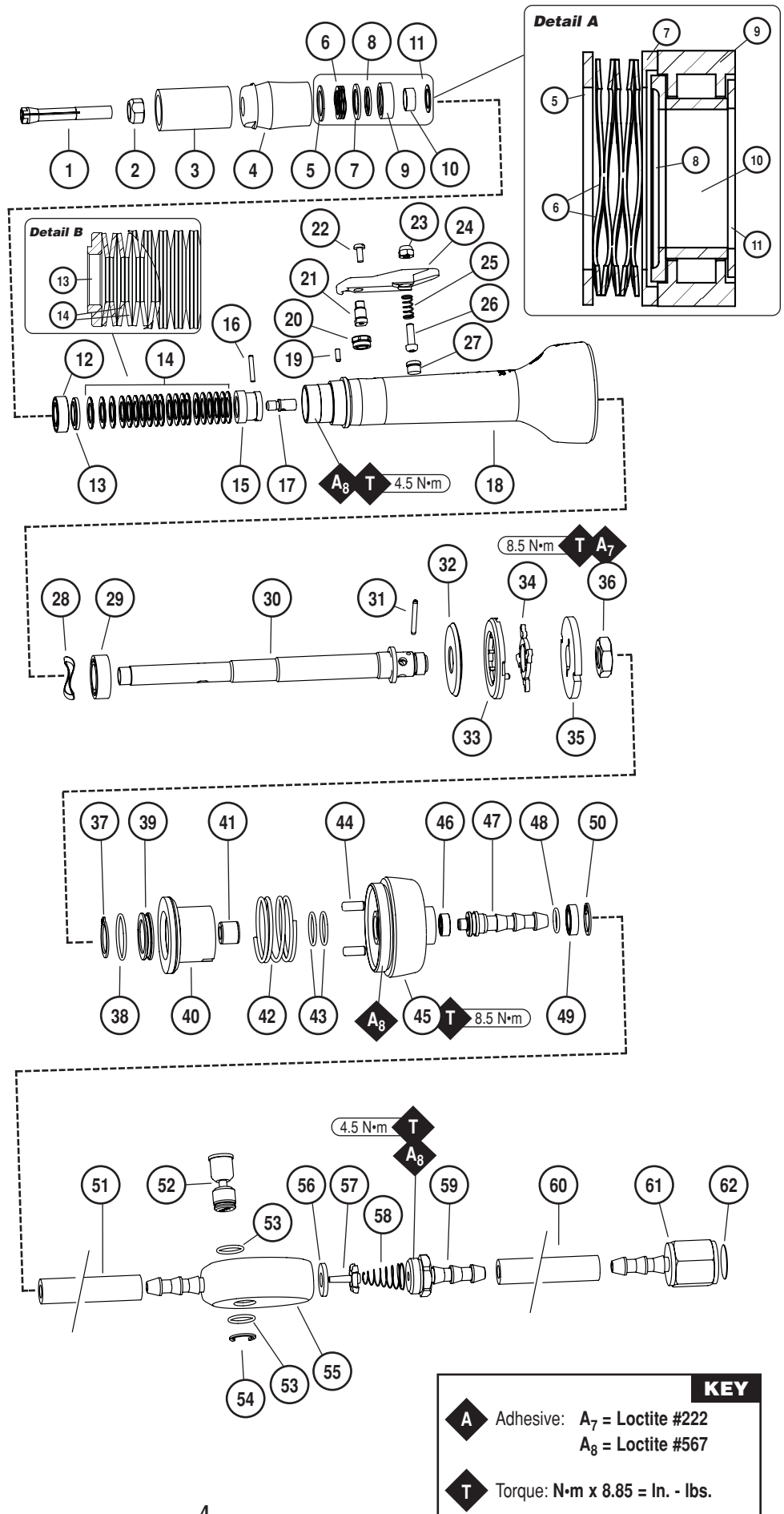

Disassembly/Assembly Instructions - Wrenchless Pencil Grinder

Important: The Dynabrade Pneumatic Power Tool Lifetime Warranty Policy does NOT cover normally wearable parts and products. Before servicing this tool please contact Dynabrade Inc. or a Dynabrade Subsidiary for information regarding the Dynabrade Pneumatic Power Tool Lifetime Warranty Policy.

Notice: Special repair tooling referred to in these instructions can be ordered from Dynabrade.

DISCONNECT AIR SUPPLY BEFORE ANY MAINTENANCE OR SERVICE.

Collet Disassembly/Assembly Instructions

To Disassemble:

1. Rotate Lever **60083** counterclockwise and open collet.
2. To loosen and remove the collet insert, turn it counterclockwise.

To Assemble:

1. To reduce accessory run-out and sticking; thoroughly clean, inspect, and polish as necessary, the **60076/60108** Collet Insert, and the collet body end of the drive shaft.
2. Install an accessory with the correct diameter shank into the collet insert. Turn the collet insert clockwise to secure the accessory in the collet. Note: Tighten the collet insert around the shank of the accessory until a precise slip fit is established.
3. Rotate the **60083** Lever clockwise until it locks, securing the accessory in the collet.

Motor Disassembly/Assembly Instructions

To Disassemble:

1. To remove the **60110/60067** Swivel Cover, place an adjustable pin spanner wrench in the exhaust holes of the swivel cover and turn it counterclockwise. Note: Moderate heat may be necessary to soften the thread sealant.
2. To remove the **60099** Hex Nut, insert a 4 mm hex key into the internal hex recess in the turbine end of the drive shaft. Hold it stationary with the hex key and use an adjustable wrench to remove the hex nut. Turn it counterclockwise.
3. Remove the **60069** Brake Plate, **51691/51675** Governor, and the **51678** Turbine.
4. Remove the **60068** Drive Shaft from the housing.
5. Remove the **60098** Pin and the **51656** Turbine Base.

To Assemble:

1. Install the **51656** Turbine Base onto the drive shaft.
2. Press the **60098** Pin into the cross-drilled hole in the drive shaft. Centralize the pin in the drive shaft.
3. Install the **51678** Turbine, and the **51691/51675** Governor onto the drive shaft.
4. To install the **60069** Brake Plate, align the slot in the brake plate with the **60098** Pin, and the notches with the **51678** Turbine.
5. Apply a small amount of Loctite #222 (or equivalent) to the hex nut threads on the drive shaft. Tighten the **60099** Hex Nut onto the drive shaft. (Torque to 4.5 N•m/40 in. lbs.)
6. Install the drive shaft assembly into the housing.
7. Apply a small amount of the Loctite #567 (or equivalent) to the threads of the **60110/60067** Swivel Cover. Install the swivel cover onto the housing and tighten. (Torque to 8.5 N•m/75 in. lbs.)

Motor Disassembly/Assembly Complete.

Bearing Replacement Instructions

(Use only Dynabrade specified replacement bearings.)

To Remove:

1. (Follow Collet Disassembly Instructions)
2. To replace the **60093** Bearing, and the **51651** Bearing, remove the **60066** Nose Piece. Turn it counterclockwise. Note: The **60081** Washer, **60102** Spring, and **60087** Washer Seal can be removed with the nose piece.
3. Remove the **60077** Bumper. Turn it counterclockwise.
4. Important: Note the orientation of the following parts as they are removed. These parts must be installed in the same manner as they are removed. – Carefully remove the; **60088** Front Seal, **60089** Outer Housing Seal, **60090** Inner Race Seal, and **60092** Rear Seal.
5. Remove the; **60107** Screw, **60082** Cam, **60083** Lever, and **60080** Cam Support from the housing.
6. Use an adjustable pin spanner wrench in the exhaust holes of the **60110/60067** Swivel Cover to remove it from the housing. Note: Moderate heat may be necessary to soften the thread sealant.
7. Carefully remove the drive shaft with turbine air motor, the **51661** Wave Washer, the **60074** End Support, and the twenty [20] **60073** Spring Washers from the housing.
8. Remove the **60093** Bearing from the housing.
9. Use the **96346** Bearing Separator, and the **96232** Arbor Press [#2] to remove the **51651** Bearing from the drive shaft.

To Install:

1. Use the arbor press and the raised inside diameter of the **96418** Bearing Press Tool to install the **51651** Bearing onto the drive shaft.
2. If the **60074** End Support and/or **60073** Spring Washers [20] (conical shaped spring washers) have been separated from the drive shaft, they should be installed onto the drive shaft at this point. Orient the two end conical shaped spring washers with their large diameter against the end supports. The remainder of the conical shaped spring washers should be installed small diameter to small diameter, and large diameter to large diameter in alternating fashion. (See Detail B)
Note: Do not nest the **60073** Spring Washers.
3. Install the **51661** Wave Washer into the housing, and install the drive shaft and bearing. Be careful not to lose the end support and spring washer stack-up. Note: The **51651** Bearing should be a slip fit into the bore of the housing. If it is not a slip-fit, use very fine abrasive cloth to polish the bearing bore.
4. Rest the **60099** Hex Nut on the tool plate of the **96232** Arbor Press [#2] with the collet body end of the drive shaft pointing up. Place the **60093** Bearing over the collet body end of the drive shaft so that it drops into the housing. Use the raised outside diameter of the **96419** Bearing Press Tool to install the bearing into the housing.
5. Install the; **60092** Rear Seal Washer, **60090** Inner Race Seal, **60089** Outer Housing Seal, **60088** Front Seal Washer.
6. Install the **60077** Bumper until it bottoms.
7. Install the; **60081** Washer, **60102** Flat Wire Compression Spring, **60087** Seal Washer so that they are properly positioned in the **60066** Nose Piece. (See Detail A)
8. Apply a small amount of the Loctite #567 (or equivalent) to the threads of the housing.
9. Install the nose piece with parts onto the housing. (Torque to 4.5 N•m/40 in. lbs.)
10. Apply a small amount of the Loctite #243 (or equivalent) to the threads of the **60107** Screw and install the **60082** Cam and **60083** Lever onto the housing.
11. Install the **60076/60108** Collet Insert, into the collet body end of the drive shaft. Note: Adjust the collet as stated in **Collet Assembly Steps #2 & 3**.

Bearing Replacement Instructions Complete.

Air Bushing Replacement (The **51662** Air Bushing should be replaced every time the tool is serviced.)

1. To replace the **51662** Air Bushing, use an Easy Out Screw Extractor, or another means to remove it from the swivel cover.
2. Carefully press a new **51662** Air Bushing into the swivel cover. Leave approximately 1/16" (1.5 mm) standing above the edge of the swivel cover. Join the swivel cover to the housing, turning the cover until it bottoms against the housing. Next back the cover off slightly until the drive shaft rotates freely. Carefully connect the tool to the air supply and depress the "ON" button. As the tool is running slowly tighten the swivel cover to 'wear-in' the air bushing. Once the swivel cover is bottomed against the housing and the tool is running freely, depress the "OFF" button, wait for the drive shaft to stop, and disconnect the tool from the air supply. – Remove the swivel cover from the housing. Apply a small amount of the Loctite #567 (or equivalent) to the threads of the **60110/60067** Swivel Cover. Join and tighten the swivel cover to the

housing. (Torque to 8.5 N•m/75 in. lbs.)

3. Test the air motor for proper operation. Important: Always check RPM without an accessory mounted in the tool. Carefully connect the tool to the air supply. Activate the "ON" button. Use a tachometer to check the speed (RPM) of the tool. The tool should operate within 10% of the rated maximum RPM that is marked on the housing. The tool speed should not exceed the maximum RPM with operating air pressure set to 90 psig. (6.2 Bar) at the air inlet of the tool.

Brake Replacement

To Remove:

1. To remove the 60110/60067 Swivel Cover, place an adjustable pin spanner wrench in the exhaust holes of the swivel cover and turn it counterclockwise. Note: Moderate heat may be necessary to soften the thread sealant.
2. Use external retaining ring pliers to remove the 60103 External Retaining Ring and the 60072 Brake Assembly.
3. Remove the 60075 Backing Plate from the bore of the 60072 Brake Assembly.

To Install:

1. Inspect all O-Ring seals and replace any that are damaged.
2. Make sure that the 60097 Compression Spring is in place. Lubricate the O-Ring seals with, 95842 Dynabrade Air Lube (10W/NR). Install the new 60072 Brake Assembly with the notches aligned to engage the 60100 Pins (2).
3. Lubricate the O-Ring seals on the 60075 Backing Plate with 95842 Dynabrade Air Lube (10W/NR). Insert the backing plate into the bore of the 60072 Brake Assembly.
4. Use external retaining ring pliers to secure the 60075 Backing Plate with the 60103 External Retaining Ring. Make sure to engage the retaining ring groove in the swivel cover.
5. Apply a small amount of the Loctite #567 (or equivalent) to the threads of the 60110/60067 Swivel Cover. Join and tighten the swivel cover to the housing. (Torque to 8.5 N•m/75 in. lbs.)

Hose Instructions (To repair or replace damaged hose):

To Remove:

1. Use a sharp utility knife to cut the hose length-wise, approximately 1" (25 mm) from the end of the tool or valve body. Remove the hose.
2. Trim away the damaged area of the hose, or replace the damaged hose with a new section of 51276 or 51277 Hose. Important: Use only Dynabrade Push-Lock Hose.

To Install:

3. Push the hose firmly onto the Push-Lock hose barb fitting. Push the hose all the way on, tight against the mating part.

Hose Repair/Replacement Complete.

Test the air motor for proper operation. **Important:** Always check RPM without an accessory mounted in the tool. – Carefully connect the tool to the air supply. Activate the "ON" button. Use a tachometer to check the speed (RPM) of the tool. The tool should operate within 10% of the rated maximum RPM that is marked on the housing. The tool speed should not exceed the maximum RPM with operating air pressure set to 90 psig. (6.2 Bar) at the air inlet of the tool.

Preventative Maintenance Schedule

For All Wrenchless Pencil Grinders

PART TYPE LEGEND

L Easily lost. Care during assembly/disassembly.

This service chart is published as a guide to expectant life of component parts. The replacement levels are based on average tool usage over one year. Dynabrade Inc. considers one year usage to be 1,000 hours.

Index #	Part Number	Description	Number Required	Part Wear	Part Type
1	See Note	Collet Insert	1	30%	–
2	60077	Bumper	1	10%	–
3	60106	Tactile Grip	1	10%	–
4	60066	Nose Piece	1	10%	–
5	60081	Washer	1	10%	–
6	60102	Spring	1	10%	–
7	60087	Seal Washer	1	10%	–
8	60088	Front Seal Washer	1	10%	–
9	60089	Outer Housing Seal	1	10%	–
10	60090	Inner Race Seal	1	10%	–
11	60092	Rear Seal Washer	1	10%	–
12	60093	Bearing	1	70%	–
13	60074	End Support	1	10%	–
14	60073	Spring	20	10%	–
15	60078	Spring Compressor	1	10%	–
16	60079	Collet Adjustment Screw	1	30%	–
17	See Note	Housing	1	10%	–
18	60091	Pin	1	10%	L
19	60095	Pin	1	10%	L
20	60080	Cam Support	1	10%	–
21	60082	Cam	1	30%	–
22	60107	Screw	1	10%	L
23	60101	Lock Nut	1	10%	–
24	60083	Lever	1	10%	–
25	60085	Spring	1	10%	–
26	60084	Plunger	1	30%	–
27	60096	Detent Guide	1	10%	–
28	51661	Wave Washer	1	10%	–
29	51651	Bearing	1	70%	–
30	60068	Drive Shaft	1	10%	–
31	60098	Pin	1	10%	–

Index #	Part Number	Description	Number Required	Part Wear	Part Type
32	51656	Turbine Base	1	10%	–
33	51678	Turbine	1	30%	–
34	See Note	Governor	1	30%	–
35	60069	Brake Plate	1	10%	–
36	60099	Hex Nut	1	10%	–
37	60105	O-Ring	1	30%	–
38	60075	Backing Plate	1	10%	–
39	60072	Brake Assembly	1	30%	–
40	51662	Bushing	1	100%	–
41	60097	Spring	1	10%	–
42	60103	Retaining Ring	1	70%	–
43	60104	O-Ring	2	30%	–
44	60100	Pin	2	10%	–
45	See Note	Swivel Cover	1	10%	–
46	10967	Bearing	1	30%	–
47	10966	Swivel Barb	1	10%	–
48	10972	O-Ring	1	10%	–
49	10968	Bearing	1	30%	–
50	95998	Retaining Ring	1	70%	–
51	51276	Hose (24in.)	1	30%	–
52	51665	On/Off Valve	1	10%	–
53	95730	O-Ring	2	30%	–
54	51669	Retaining Ring	1	70%	–
55	51282	Valve Body	1	10%	–
56	51664	Valve Seat	1	10%	–
57	51663	Tip Valve	1	10%	–
58	51676	Spring	1	10%	–
59	51271	Barb Fitting	1	10%	–
60	51277	Hose (xxin.)	1	30%	–
61	51269	Barb Fitting	1	10%	–
62	56022	Inlet Screen	1	30%	–

Note: Please refer to page 4 of tool manual for specific part number and description.

Pencil Grinder Reference Tables

Note: Reprinted with permission of United Abrasives Manufacturers Association From (ANSI B7.1). For more information on other type mounted wheels refer to (ANSI B7.1) Safety requirements for use, care and protection of Abrasive wheels.

Table 27 – Group W — (plain wheels) Maximum operating speeds (RPM) for 1/8" mandrels

Shape No.	D Wheel Diameter Inches	T Wheel Thickness Inches	1/2" Overhang & Thd. Mdlis.	Overhang — Dimension O*			
				1"	1-1/2"	2"	2-1/2"
W 143	1/8	1/8	102,200	74,340	57,320	43,010	29,780
W 144	1/8	1/4	92,460	66,130	50,640	37,850	26,160
W 145	1/8	3/8	84,190	59,390	45,430	34,170	24,000
W 146	1/8	1/2	76,820	53,550	41,120	31,390	22,760
W 151	3/16	1/8	91,740	64,700	48,490	35,000	22,580
W 152	3/16	1/4	82,070	56,560	41,880	29,920	19,030
W 153	3/16	3/8	73,880	49,890	36,740	26,310	16,960
W 154	3/16	1/2	66,580	44,130	32,510	23,600	15,780
W 157	1/4	1/16	91,700	64,710	48,560	35,110	22,750
W 158	1/4	1/8	84,930	58,700	43,310	30,630	19,040
W 159	1/4	3/16	79,850	54,390	39,770	27,850	17,020
W 160	1/4	1/4	75,330	50,640	36,780	25,630	15,560
W 161	1/4	5/16	71,150	47,210	34,120	23,730	14,430
W 162	1/4	3/8	67,210	44,040	31,710	22,090	13,550
W 163	1/4	1/2	59,990	38,350	27,550	19,460	12,450
W 164	1/4	3/4	47,880	29,300	21,550	16,520	12,450
W 165	5/16	1/16	86,320	60,140	44,800	32,170	20,630
W 166	5/16	1/8	79,580	54,170	39,590	27,730	16,950
W 167	5/16	1/4	70,060	46,170	33,130	22,800	13,540
W 168	5/16	5/16	65,900	42,790	30,510	20,940	12,450
W 169	5/16	3/8	62,010	39,650	28,140	19,330	11,610
W 170	5/16	1/2	54,860	34,040	24,050	16,770	10,580
W 171	5/16	3/4	42,890	25,130	18,200	13,980	10,850
W 172	3/8	1/16	81,660	56,300	41,780	29,960	19,230
W 173	3/8	1/8	74,960	50,360	36,600	25,560	15,590
W 174	3/8	1/4	65,510	42,440	30,210	20,690	12,260
W 175	3/8	3/8	57,530	35,990	25,290	17,300	10,400
W 176	3/8	1/2	50,460	30,450	21,280	14,820	9,440
W 177	3/8	3/4	38,640	21,690	15,570	12,170	9,850
W 178	3/8	1	29,760	15,870	12,810	12,470	12,130
W181	1/2	1/16	73,440	49,710	36,820	26,640	17,540
W 182	1/2	1/8	66,810	43,850	31,720	22,300	13,970
W 183	1/2	1/4	57,510	36,070	25,470	17,590	10,780
W 184	1/2	3/8	49,680	29,770	20,700	14,340	9,070
W 185	1/2	1/2	42,750	24,370	16,830	12,000	8,260
W 186	1/2	3/4	31,220	15,900	11,420	9,650	8,960
W 187	1/2	1	22,630	10,370	8,950	7,530	6,110
W 190	5/8	1/16	61,120	43,850	32,590	24,040	16,570
W 191	5/8	1/8	59,390	38,060	27,560	19,780	13,070
W 192	5/8	1/4	50,240	30,430	21,460	15,210	10,030
W 193	5/8	3/8	42,550	24,280	16,840	12,110	8,470
W 194	5/8	1/2	35,770	19,020	13,110	9,920	7,800
W 195	5/8	3/4	24,530	10,840	7,990	7,850	7,710
W 196	5/8	1	16,240	5,610	5,100	5,100	5,100
W 199	3/4	1/16	50,930	38,360	28,730	21,810	15,970
W 200	3/4	1/8	50,930	32,640	23,770	17,620	12,550
W 201	3/4	1/4	43,330	25,150	17,820	13,190	9,650
W 202	3/4	3/8	35,790	19,150	13,340	10,240	8,230
W 203	3/4	1/2	29,150	14,040	9,760	8,190	7,710
W 204	3/4	3/4	18,210	6,150	4,930	3,710	2,490
W 210	7/8	1/16	43,650	33,070	25,070	19,780	15,580
W 211	7/8	1/8	43,650	27,420	20,190	15,670	12,230
W 212	7/8	1/4	36,630	20,090	14,380	11,390	9,480
W 213	7/8	3/8	29,240	14,220	10,050	8,580	8,200
W 215	1	1/8	38,200	22,340	16,740	13,850	12,040
W 216	1	1/4	30,060	15,150	11,080	9,710	9,430

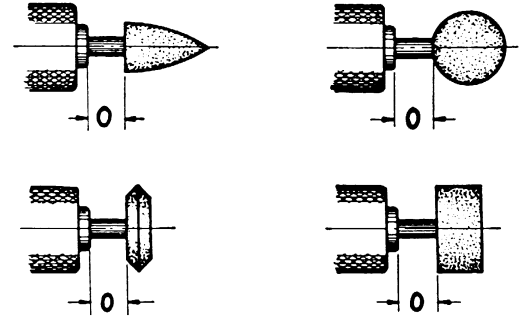

FIGURE NO. 47
Dimension "O" indicates overhang of mandrel.

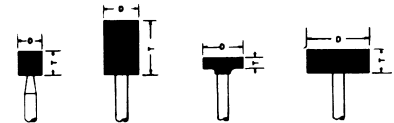

ILLUSTRATION No. 80
MOUNTED WHEELS
STANDARD SHAPES
GROUP "W"

Optional Accessories

FIND THE MOST CURRENT OFFERING OF SUPPORT DOCUMENTS AND ACCESSORIES @ WWW.DYNABRADE.COM



- Model 10677:** 55 SCFM @ 145 PSIG
3/8" or 1/2" NPT Female ports.
- Filter-Regulator, provides accurate air pressure regulation and two stage filtration of water/contaminates.



- Model 93351**
- 1/8" Carbide Burr Kit, Includes 12 burrs for grinding, deburring, and finishing metal.

Special Repair Tools

- 96418** Bearing Press Tool
(.623" O.D., .375" I.D.)

Machine Specifications

Model Number	Motor RPM	Sound Level	Maximum Air Flow SCFM (LPM)	Air Pressure PSIG (Bars)	Collet Size	Weight Pound (kg)	Length Inch (mm)	Height Inch (mm)
60051	60,000	77 dB(A)	8 (227)	90 (6.2)	1/8"	1 (.45)	5-5/16 (136)	1-1/2 (37)
60052	35,000	65 dB(A)	8 (227)	90 (6.2)	3/32"	1 (.45)	5-5/16 (136)	1-1/2 (37)

Additional Specifications: Air Inlet Thread 1/4" NPT • Hose Size 1/4" (6 mm)

Sound Level is the pressure measurement according to the method outlined in ISO regulation ISO-15744

Reference Contact Information

- American National Standards Institute – ANSI**
25 West 43rd Street
Forth Floor
New York, NY 10036
Tel: 1 (212) 642-4900
Fax: 1 (212) 398-0023
- Government Printing Office – GPO**
Superintendent of Documents
Attn. New Orders
P.O. Box 371954
Pittsburgh, PA 15250-7954
Tel: 1 (202) 512-1803
- European Committee for Standardization**
Rue de Stassart 36
B - 1050 Brussels, Belgium



Visit Our Web Site: www.dynabrade.com

Email: Customer.Service@Dynabrade.com

DYNABRADE, INC., 8989 Sheridan Drive • Clarence, NY 14031-1490 • Phone: (716) 631-0100 • Fax: 716-631-2073 • International Fax: 716-631-2524
DYNABRADE EUROPE S.à.r.l., Zone Artisanale • L-5485 Wormeldange—Haut, Luxembourg • Telephone: 352 76 84 94 1 • Fax: 352 76 84 95 1